

CORPORATE HEADQUARTERS

SERVICE DEPARTMENT

CUSTOMER SALES COUNTER

DISTRIBUTION CENTER

559-233-6684
2825 S. Elm Ave. #101
Fresno, CA 93706

BAKERSFIELD

Open All Day Saturday
661 322-9353
5150 Rosedale Hwy
Bakersfield, CA 93308

CITRUS HEIGHTS

Open All Day Saturday
916 560-2006
6005 Auburn Blvd. #100
Citrus Heights, CA 95621

CLOVIS

Open All Day Saturday
559 292-1234
2742 Clovis Ave.
Clovis, CA 93612

FRESNO

Open All Day Saturday
559 233-9353
2701 E. Jensen Ave.
Fresno, CA 93706

MADERA

Open till noon Saturdays
559 718-2072
311 S. Pine Street #101
Madera, CA 93637

MODESTO

Open till noon Saturdays
209 491-2780
1501 Coldwell Ave.
Modesto, CA 95350

PORTERVILLE

Open till noon Saturdays
559 782-1025
1204 W. Olive
Porterville, CA 93257

SACRAMENTO

Open All Day Saturday
916 456-2478
4218 Power Inn Rd
Sacramento, CA 95826

WEST SACRAMENTO

Open All Day Saturday
916 913-0902
501 Harbor Blvd., Suite A
West Sacramento, CA 95605

NOW OPEN!

SALINAS

Open All Day Saturday
831 783-1806
1040 Abbott St.
Salinas, CA 93901

STOCKTON

Open All Day Saturday
209 463-9353
1444 E. Mariposa Rd.
Stockton, CA 95205

TURLOCK

Open till noon Saturdays
209 216-5592
1105 Lander Ave.
Turlock, CA 95380

VISALIA

Open till noon Saturdays
559 733-2335
2239 E. Main St.
Visalia, CA 93292



Division of Fresno Oxygen

MONTHLY SPECIAL FLYER

APRIL 2024



1949 - 2024



PLASMA CUTTERS

POWERMAX30® AIR

PART# HYP088096

Rated Input:
120-240V, 1-Phase
Rated Output:
15-30A @ 83 VDC,
Duty Cycle @ 104°F
35%(240V), 20% (120V)
Weight: 29.8lbs

Includes: Power supply, air T30 hand torch w/ 15' lead and work clamp w/15' lead, 240 V/20 A plug with adapters for 120 V/15 A and 240 V/20 A circuits



\$2,340.00

CUT CAPACITY
Recommended Cut: 5/16"
Max Cut: 5/8"

POWERMAX30® XP

PART# HYP088079

Rated Input:
120-240V, 1-Phase
Rated Output:
15-30A @ 125 VDC,
Duty Cycle @ 104°F
35%(240V), 20%(120V)
Weight: 21.4lbs

Includes: Power supply, 15' Duramax™ LT hand torch w/ standard consumables, 15' work clamp, 240 V/20 A plug, Consumable kit w/ 1 standard nozzle, & plastic carry case



\$1,910.00

CUT CAPACITY
Recommended Cut: 3/8"
Max Cut: 5/8"



Powermax 30® Air Consumables Kit

Includes: 1 - Deflector, 1 - Retaining Cap, 7 - Nozzles, 1 - Swirl Ring, 7 - Electrodes PART# HYP851462

\$190.95



Powermax 30® XP Consumables Kit

Includes: 2 - Shields, 1 - Retaining Cap, 7 - Nozzles, 1 - Swirl Ring, 7 - Electrodes PART# HYP851479

\$196.95

POWERMAX45® XP

PART# HYP088112

Rated Input:
120-240V, 1-Phase
Rated Output:
15-30A @ 125 VDC,
Duty Cycle @ 104°F
35%(240V), 20% (120V)
Weight: 21.4lbs

CUT CAPACITY
Recommended Cut: 5/8"
Max Cut: 1-1/8"



\$2,650.00



Powermax 45® XP Consumables Kit

Includes: 2 - Shields, 1 - Retaining Cap, 7 - Nozzles, 1 - Swirl Ring, 7 - Electrodes PART# HYP851510

\$242.95

POWERMAX65 SYNC

PART# HYP083343

Rated Input:
200-480 V, 1-PH
200-600 V, 3-PH
Rated Output:
20-65A @ 139 VDC,
Duty Cycle @ 104°F
50% @ 65A, 230-600V
40% @ 65A, 200-208V
100% @ 46A, 230-600V
Weight: 61lbs

CUT CAPACITY
Recommended Cut: 3/4"
Max Cut: 1"



\$4,000.00

The Powermax65 SYNC™ is a next-generation professional grade air plasma cutter that dramatically simplifies system operation for cutting and gouging up to 20 mm (3/4"). Featuring automated system process set-up via advanced RFID-enabled SmartSYNC™ torches and a revolutionary single-piece cartridge consumable that provides trackable utilization data. The Powermax65 SYNC maximizes productivity through reductions in downtime, optimized cut quality performance and streamlined consumable inventory management.



synchrony

6 OR 12 MONTHS* DEFERRED INTEREST

MORE FINANCING AVAILABLE



SCAN QR CODE FOR DETAILS!



www.barnesweldingsupply.com
E-mail: info@barneswelding.com



HOLE EXPANSION

SET Type 51-UB

Car Reamer - Fast Spiral Hole Buster™, Super Premium 3 flats on shank

PART# VDT12271

\$233⁹⁵



VIKING DRILLS

STEP DRILLS ULTRA BIT™

Multi-Diameter Type 78-UB Gold Oxide



1/8 - 1/2"

PART# VDT00700

1/4 - 3/4"

PART# VDT00703

\$22⁹⁵

\$29⁹⁵

VORTEX POINT 29 PIECE DRILL BIT SET

- Enlarge existing holes or drill through sheet metal, hard steel, acrylics and brass. Self-centering and 3-flats on shank.
- Ultra bor super premium sizes: 1/16" - 1/2" by 64ths

PART# VDT22903

\$181⁹⁵



MECHANICS LENGTH, 3/8" REDUCED SHANK 29 PIECE DRILL BIT SET

- 135° split point
- Ultra bor super premium sizes: 1/16" - 1/2" by 64ths

PART# VDT57950

\$137⁹⁵



29PC - ULTRA CUT SUPER PREMIUM SPECIAL HI-MOLYBDENUM STEEL DRILL SET

- Sizes: 1/16 thru 1/2 by 64ths
- 135° split point

PART# VDT44150

\$110⁹⁵



40 PIECE TAP AND DIE SET

HSS spiral point taps & HSS hex dies sizes: 4-40, 6-32, 8-32, 10-24, 10-32, 12-24, 1/4-20, 1/4-28, 5/16-18, 5/16-24, 3/8-16, 3/8-24, 7/16-14, 7/16-20, 1/2-13 & 1/2-20

PART# VDT35181

\$321⁹⁵

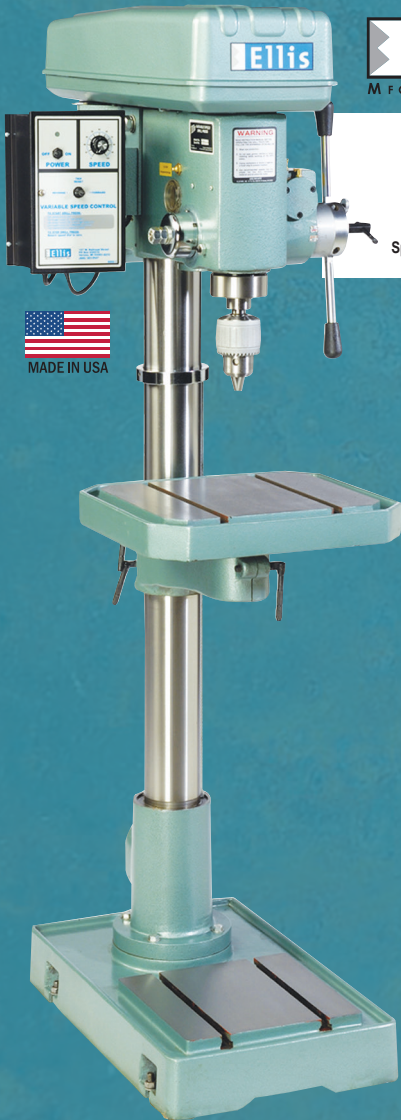

9400 DRILL PRESS

Infinitely Variable Speed

- Adjust speeds while operating in the material
- Instantaneous reversing for tapping
- Variable speed from 0 to 1200 rpm
- High torque at low rpm speeds

PART# ELL9400

Drill shown with Chuck (which is sold separately)

\$4,718⁹⁵



3/4" CHUCK W/ ARBOR ADAPTER

PART# ELL4649

\$199⁹⁵

8 PIECE DRILL SET

1/2" Shank Silver and Deming

- Special Hi-Molybdenum tool steel.
- 135° split point
- Sizes larger than 3/4" dia, have 118° split point
- Sizes: 9/16 thru 1 inch by 16ths
- Type 280-UB, Ultra Bor Super Premium, 3 Flats on Shank

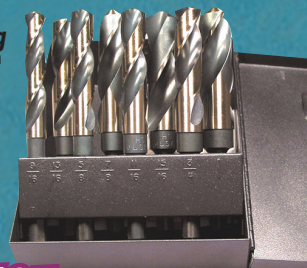

\$267⁹⁵

PART# VDT92400



CHAMPION

CARBIDE TIPPED HOLE SAWS

The Ultimate Hole Cutting Saw for Thick Steel

For Steel Plate, Iron, Aluminum, Copper, Cast Iron & Stainless Steel up to 1" thick

PILOT DRILL \$7⁹⁵

PART# CCTC7-PILOT



SIZE	PART#	PRICE
5/8"	CCT-C7-5/8	\$45⁹⁵
11/16"	CCT-C7-11/16	\$40⁹⁵
3/4"	CCT-C7-3/4	\$48⁹⁵
13/16"	CCT-C7-13/16	\$48⁹⁵
7/8"	CCT-C7-7/8	\$48⁹⁵
15/16"	CCT-C7-15/16	\$48⁹⁵
1"	CCT-C7-1	\$48⁹⁵
1-1/16"	CCT-C7-1-1/16	\$52⁹⁵
1-1/8"	CCT-C7-1-1/8	\$52⁹⁵
1-3/16"	CCT-C7-1-3/16	\$61⁹⁵
1-1/4"	CCT-C7-1-1/4	\$61⁹⁵
1-3/8"	CCT-C7-1-3/8	\$61⁹⁵
2"	CCT-C7-2	\$81⁹⁵

4 1/2" ANGLE GRINDER

- 11 Amp AC/DC 11,000 rpm motor
- Dust Ejection System™

PART# DWTDWE402N



\$84⁹⁵



HEAVY-DUTY 1/2" DRILL

PART# DWTWD235G



- Variable Speed, Reversible; 7.8A; 0-850 rpm
- Two-finger, rubber trigger. 360° side handle

\$148⁹⁵

HIGH PERFORMANCE TRIGGER GRIP 4 1/2" - 5" GRINDER

- Quick-Change wheel release / keyless adjustable guard
- 13.0Amp, 2.3 HP, 9,000 rpm motor
- Dust ejection system™



PART# DWTDWE43115N

\$179⁹⁵

HEAVY-DUTY, HIGH PERFORMANCE 4 1/2" - 5" ANGLE GRINDER

PART# DWTDWE43114N

- 13.0 amp / 2.3 HP, 11,000 RPM
- G55 (AC) motor
- Complete Electronic Control™



\$170⁹⁵

1/2" SPADE HANDLE DRILL

- 9.0Amps, 120V motor
- 0-550rpm provides increased torque

PART# DWTWD130V



\$214⁹⁵



1/2" MAGNUM DRILL

- 8.0Amps, 120V motor
- 0-850 rpm

PART# MLW0299-20

\$143⁹⁵

UNITED ABRASIVES, INC.

SAIT GRINDING WHEELS

Type 27

- Aluminum oxide grain
- Soft bond for fast stock removal



DIA/THICK/ARBOR	GRADE	PART#	
4-1/2 x 1/4 x 7/8 13300 Max RPM	A24R	ABR20063	\$2⁹⁵
5 x 1/4 x 7/8 12200 Max RPM	A24N	ABR20070	\$4⁹⁵

GRINDING WHEELS Z-TECH™

High Performance

Type 27

- Special zirconium grain formula
- Hard bond for extremely long life
- Fast, burr-free cutting



DIA/THICK/ARBOR	PART#	
4-1/2 x .045 x 7/8 13300 Max RPM	ABR23334	\$3²⁵
5 x .045 x 7/8 12200 Max RPM	ABR23335	\$3⁷⁵

WENDT

"BIG BOY"

ULTIMATE ZIRCONIA HI-DENSITY FLAP DISCS

with Fiberglass Backing

Dia x Arbor: 4-1/2"x7/8"

(40 grit)	PART# WEN235112	\$5⁴⁹ ea
(60 grit)	PART# WEN235113	
(80 grit)	PART# WEN235114	



VARIABLE SPEED, REVERSIBLE 1/2" DRILL



- Heavy duty 1/2" drill chuck
- Variable speed for controlled drilling (0-550RPM)
- Powerful 6.5A motor

PART# MAK6302H

\$174⁹⁵

VARIABLE SPEED, REVERSIBLE 3/8" DRILL



- Keyless chuck
- Large trigger switch
- 4.9 AMP motor (115V)
- Variable speed (0-2,500rpm)
- Large recessed lock-on button
- Capacities: 3/8" Steel; 1" Wood

PART# MAK6408

\$99⁹⁵

1/2" SPADE HANDLE DRILL

- Powerful 8.5A motor
- 600 RPM

PART# MAKDS4011

\$210⁹⁵



Electronic Speed Control 7" SANDER/POLISHER

- Preset speed setting dial: 600 to 3,000 RPM for maximum control
- Electronic speed control maintains constant speed under load. Easily converts to a sander
- 3 prong plug to prevent static electricity accumulation. Fast and powerful polishing
- Variable speed with preset maximum speed dial
- Lock-on button

\$298⁹⁵

Includes:
7" H&L Wool Compound Pad,
7" H&L Blended Polishing Pad,
Nylon Tool Bag



4 1/2" - 5" ANGLE GRINDER

- 11 AMP motor delivers 11,000 RPM
- Compact design for added comfort

PART# MAKGA5052

\$99⁹⁵



April's Monthly Special Flyer

Look throughout our Store for these Specially Marked **SALE** Items!



BENCH GRINDERS

- UL Listed motor
- Adjustable Tool Rest
- Pre-Lubricated and Enclosed Ball Bearings
- Cast Iron Wheel Guards and Dust Vents
- One Piece Quick Adjusting Spark Guards
- Large Eye Shields with Quick Adjustments
- Heavy-Duty Guarded Toggle Switch on 8" & 10" Models
- Rubber Mounts Prevent Movement

6" x 3/4" x 1/2"

1/2 HP - 115 Volt PART# JETJBG-6A

\$246⁹⁵

8" x 1" x 5/8"

1 HP - 115 Volt PART# JETJBG-8A

\$334⁹⁵



Division of Fresno Oxygen

PO Box 1666, Fresno, CA 93717

CHANGE SERVICE REQUESTED

7" X 12" DELUXE HORIZONTAL/VERTICAL BANDSAW

- Large 10" x 12" infeed table assembly
- Multi-position blade
- 3/4" bi-metal blade
- Tool-less quick lock vise

PART# JETHVBS-712D



Cutting Capacity: 7X12
 Blade Size: 3/4" x 0.032 x 93"
 Blade Speeds: 86-132-178-260 SFPM
 Height of Work Table: 23-1/2"
 Motor: 3/4 HP, 115/230V, 1-phase
 Dimensions: 48" L x 17" W x 44" H
 Net Weight: 418 lbs



\$1,999⁹⁵

HORIZONTAL/VERTICAL BANDSAW

- Blade size: 5'x4-1/2"x1/2"x.025
- 1/2HP motor
- UL listed 1 phase, 115/230v prewired 115V
- 5"x6" capacity
- Heavy-Duty 14-gauge steel stand
- Automatic shut-off after cut
- Wheels and handle for easy movement
- Ball bearing supported blade wheel
- Fully adjustable ball bearing blade guides
- Vertical work table
- Adjustable material stop
- Handle and wheels for easy movement
- Blade drive is a sealed, steel, heat treated worm driving a bronze worm gear in an oil bath.



PART# JETHVBS-56M

\$769⁹⁵

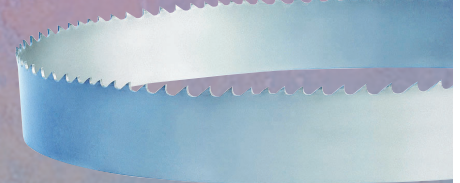

BANDSAW BLADES MORSE

THE M. K. MORSE COMPANY

For use with Jet HVBS-56M
 BLADE SIZE TEETH

5'- 4-1/2"x1/2"x.025 14R **\$15⁹⁵**
 PART# MORHB-54121214

5'- 4-1/2"x1/2"x.025 14R **\$27⁹⁵**
 PART# MORBM-54121214 Bi-Metal

For use with Jet HVBS-712D

7' 9" x 3/4" x .035 6/10VT **\$41⁹⁵**
 PART# MORM42-7934812 Bi-Metal

7'- 9" x 3/4" x .035 10/10VT **\$39⁹⁵**
 PART# MORBM-79341014 Bi-Metal

FR WELDING JACKETS

- BSX™ Tuned for Performance and Style
- 9 oz. FR Cotton with stand-up collar
- Extended front coverage
- Adjustable cuffs



**Black w/
Red Lines**

Dual scribe and inside pockets. One inside pocket has a zipper closure. Adjustable waist straps.
PART# REV89C

SIZES
Med - XL
\$3249
ea

SIZES XXL
\$3348

SIZES XXL
\$3449

PREMIUM PIGSKIN PALM
W/ COWHIDE BACK

MIG WELDING GLOVES

Exclusive DragPatch® and RestPatch®

PART# REVBM88

Sizes Med - XLG

\$2249
ea



WELDERS CAPS

- Reversible Design (Printed / Solid Color)
 - Super soft trim
- Available in assorted designs and colors

COME AUX CAPS

SIZE	PART#
7"	IWD20700
7-1/8"	IWD20718
7-1/4"	IWD20714
7-3/8"	IWD20738
7-1/2"	IWD20712
7-3/4"	IWD20734



\$895
ea

BSX FR COTTON 19" SLEEVES

- Made of 9 oz. flame resistant cotton
- Comfortable fit with wide elastic ends

Black w/ Royal Blue
PART# REV8X9-19S-RB

Black w/ Red Flames
PART# REV8X9-19S-BK

\$1449
ea

AR/FR COTTON WORK SHIRTS

UL CLASSIFIED NFPA 2112; NFPA 70E

- Tested to maintain protection through 100 home washings
- 7 oz. FR-treated cotton with a generous comfortable fit
- Chest pockets with protective flaps and pencil slot
- Easy ID FR patch on left shoulder shirt is untucked
- Shatterproof FR melamine buttons

Khaki Plaid

PART# REVWF2110-PK

Blue Plaid

PART# REVWF2110-PB

Red Plaid

PART# REVWF2110-PR

SIZES Med - XL

\$4695
ea

SIZES XXL

\$4895
ea



BLACK STALLION

LEATHER APPAREL

Split Leg Bib Apron

Shoulder straps with quick side release buckle at waist and legs, front bib pocket, two utility D-rings.

36" Long

PART# REV36SL

\$4449

48" Long

PART# REV48SL

\$5549



40" Long Chaps

Adjustable waist strap with quick side-release buckle at waist.

PART# REV40WS

\$5349



36" Long Full Bib Apron

PART# REV36A

\$3849

FLAME RESISTANT PROTECTIVE CLOTHING

FR BrownCape Sleeves

USA-treated 12 oz. flame resistant cotton.
PART# REVFB2-21CS

SIZES M - XL

\$1795
ea

SIZES XXL

\$1895
ea



IRONWORKER KITS



Medium Duty Model 801
PART# HAR4400372

\$279⁹⁵

Heavy Duty Model 25GX
PART# HAR4400373

\$329⁹⁵

Extra Heavy Duty Model 450
PART# HAR4400374

\$489⁹⁵



HANDY PERSON TORCH KIT

- Welds up to 3/8" steel with optional larger tips
- Compatible with Victor® products
- Cuts up to 6"

PART# ASYHAR-HP-KIT

\$469⁹⁵

Kit Includes: Full Oxygen & Acetylene cylinders. You own them. 40 cf. oxygen, 40 cf. acetylene, Anthony 38-B Cylinder Cart, Harris Basic Torch Outfit

TWIN LINE WELDING HOSE

Meets all OSHA CGA & RMA standards



GRADE R for OXYGEN & ACETYLENE

1/4" x 25 ft. PART# HOS1/4-25 **\$37⁹⁵**

1/4" x 50 ft. PART# HOS1/4-50 **\$59⁹⁵**

1/4" x 100 ft. PART# HOS1/4-100 **\$116⁹⁵**

MEDIUM/ HEAVY DUTY MODEL 355 ARGON GAS FLOWMETER KIT

PART# HAR4400235



\$169⁹⁵

MEDIUM/ HEAVY DUTY MODEL 301 ARGON GAS FLOWGAUGE KIT

PART# HAR4400229



\$118⁹⁵

25GX CLAMSHELLED REGULATOR

- Medium to heavy duty Gauges
- Ergonomic knob
- 2.5" dials

Acetylene PART# HAR3000682
Oxygen PART# HAR3000681



\$109⁹⁵ ea



HOSE REPAIR KIT

Includes 1/4" & 3/16" hose ends, splicers, couplers & a crimping tool PART# HOSKIT

\$69⁹⁵



"B" 9/16" BRASS & STEEL QUICK CONNECTORS

- Shut off gas supply when disconnected
- Brass and steel

26-QCR PART# HAR4301653
26-QCT PART# HAR4301654



\$82⁹⁵ ea

OXYGEN & ACETYLENE CUTTING TIPS

Style 1-101

SIZE	PART#
000	HAR000-1-101
00	HAR00-1-101
0	HAR0-1-101
1	HAR1-1-101
2	HAR2-1-101
3	HAR3-1-101
4	HAR4-1-101



Style 3-101

SIZE	PART#
000	HAR000-3-101
00	HAR00-3-101
0	HAR0-3-101
1	HAR1-3-101
2	HAR2-3-101
3	HAR3-3-101



Original Manufacturer's Replacement Parts

Victor Style Cutting Tips

STYLE	SIZE
1-101	000 thru 4
3-101	000 thru 3

\$14⁰⁰ ea

FLASHBACK ARRESTOR

88-5 FBR with Check Valve PART# HAR4301651

- Prevent reverse flow of gases
- For oxygen and fuel gas



\$64⁹⁵